

ENERGY SOURCES AND STORAGE DEVICES

Nuclear Fission – controlled nuclear fission – nuclear fusion – differences between nuclear fission and fusion – nuclear chain reactions – nuclear energy – light water nuclear power plant – breeder reactor – solar energy conversion – solar cells - wind energy. Batteries, fuel cells and supercapacitors: Types of batteries – primary battery (dry cell) secondary battery (lead acid battery, lithium-ion-battery) fuel cells H₂-O₂ fuel cell, methanol oxygen fuel cell, SOFC and supercapacitors.

CHAPTER 8: ENERGY SOURCES

INTRODUCTION

The only clean, safe energy source capable of ensuring the continuation of our industrial civilization while protecting the environment.

by Bruno Comby

Nuclear energy is the energy that binds the protons and neutrons together in the nucleus (core) of an atom. Sometimes, a big nucleus splits into two smaller ones, releasing energy in the process. This process is called nuclear fission. The energy released is converted into heat, which can be used to drive a turbine and generate electricity.

Nuclear energy is a clean, safe, reliable and competitive energy source. It is the only source of energy that can replace a significant part of the fossil fuels (coal, oil and gas) which massively pollute the atmosphere and contribute to the greenhouse effect.

In burning fossil fuels, we inject 23 billion tons of carbon dioxide every year into the atmosphere – 730 tons per second. Half of it is absorbed in the seas and vegetation, but half remains in the atmosphere. This is significantly altering the composition of the atmosphere and seriously affecting the climate of our planet.

TYPES OF NUCLEAR REACTIONS

Nuclear Fission

It is the nuclear reaction in which heavy isotopes are split into lighter nuclei on bombardment by neutrons. Fission reaction of U^{235} is given below:

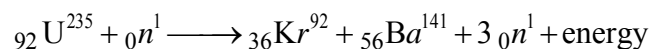

- Fission is not a spontaneous process. It can only occur when a slow moving neutron strikes an unstable nucleus.
- In this decay process, the nucleus will split into two nearly equal nuclei and release several free neutrons and huge amounts of energy.
- These nuclei are isotopes of more stable elements. If left alone, they decay radioactively by emitting alpha or beta particles.
- On average, three neutrons are released. These can go on to be absorbed by other nuclei if they are slowed down by a moderator (a medium, such as graphite, heavy water, and beryllium that causes the neutrons to travel more slowly).
- If these neutrons are absorbed by other nuclei, this causes a chain reaction.
- For the chain reaction to occur there has to be a critical mass.
- For uranium, this is about the size of a tennis ball. The critical mass has a mass of about 15 kg (uranium has a very high density, 19 g/cm^3). Anything less, the neutrons escape without setting off a chain reaction.
- If the chain reaction is not controlled, a nuclear explosion will occur.

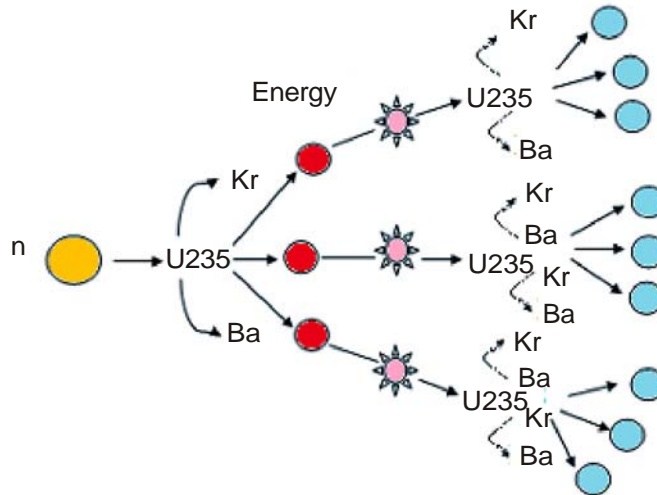
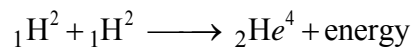

Figure 8.1 : Structure of fission reaction

Nuclear Fusion

Process of combination of lighter nuclei into heavier nucleus with simultaneous liberation of large amount of energy. (e.g) solar system.



- Nuclear fusion reaction occurs in sun.
- When fusion happens, the products have a larger binding energy than the reactants. The mass defect results in the release of huge amounts of energy.
- Actually produces more energy per gram of products than fission and produces no by-products

Why isn't it used yet then for energy production?

- It currently requires more energy to initiate the reaction than it produces.
- Heat produced is so intense that containment vessels melt.

Why does fusion require energy?

- To combine, two nuclei must be close enough for the strong nuclear force to join them. But when the positive nuclei approach, the electrostatic force of repulsion is greater than the nuclear force. This means that the nuclei must be HIGHLY energetic to overcome the repulsion force.
- This means HIGH temperatures (millions of degrees Celsius), which is difficult to achieve while containing the atoms.
- Nuclear fusion is the energy-producing process taking place in the core of the Sun and stars.
- The core temperature of the Sun is about 15 million °C. At these temperatures, four hydrogen atoms fuse in a series of reactions to form a single helium atom and give off huge amounts of energy.

DIFFERENCES BETWEEN FISSION AND FUSION REACTION

S.No	Nuclear fission	Nuclear fusion
1.	It is a process of breaking a heavier nucleous.	It is a process of combination of lighter nuclei.
2.	It emits radioactive rays	It does not emit any kind of radioactive rays
3.	The mass number and atomic number of new elements are lower than	The mass number and atomic number of product is higher than that of starting elements
4.	It occurs at ordinary temperature	It occurs at high temperature
5.	It gives rise to chain reaction	It does not give rise to chain reaction
6.	It emits neutrons	It emits positrons
7.	It can be controlled	It cannot be controlled

NUCLEAR CHAIN REACTIONS

A nuclear chain reaction occurs when one nuclear reaction causes on the average one or more nuclear reactions, thus leading to a self-propagating number of these reactions. The specific nuclear reaction may be: the *fission of heavy isotopes* (e.g. ^{235}U) or the *fusion of light isotopes* (e.g. ^2H and ^3H)

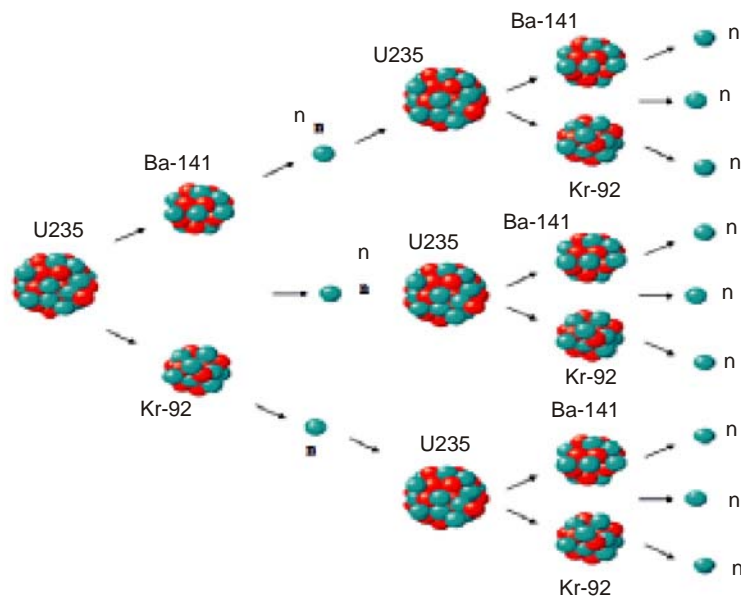

Figure 8.2 : Fission of heavy isotopes

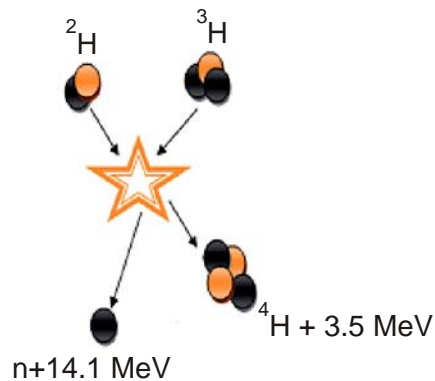

Figure 8.3 : Fusion of light isotopes

The production of 2-3 neutrons in each fission event makes it possible to use fission chain reactions for the production of energy

A schematic nuclear fission chain reaction

1. A uranium-235 atom absorbs a neutron and fissions into two new atoms (fission fragments), releasing three new neutrons and some binding energy.
2. One of these neutrons is absorbed by an atom of uranium-238 and does not continue the reaction. Another neutron is simply lost and does not collide with anything, also not continuing

the reaction. However one neutron does collide with an atom of uranium-235, which then fissions and releases two neutrons and some binding energy.

- Both of these neutrons collide with uranium-235 atoms, each of which fissions and releases between one and three neutrons, which can then continue the reaction.

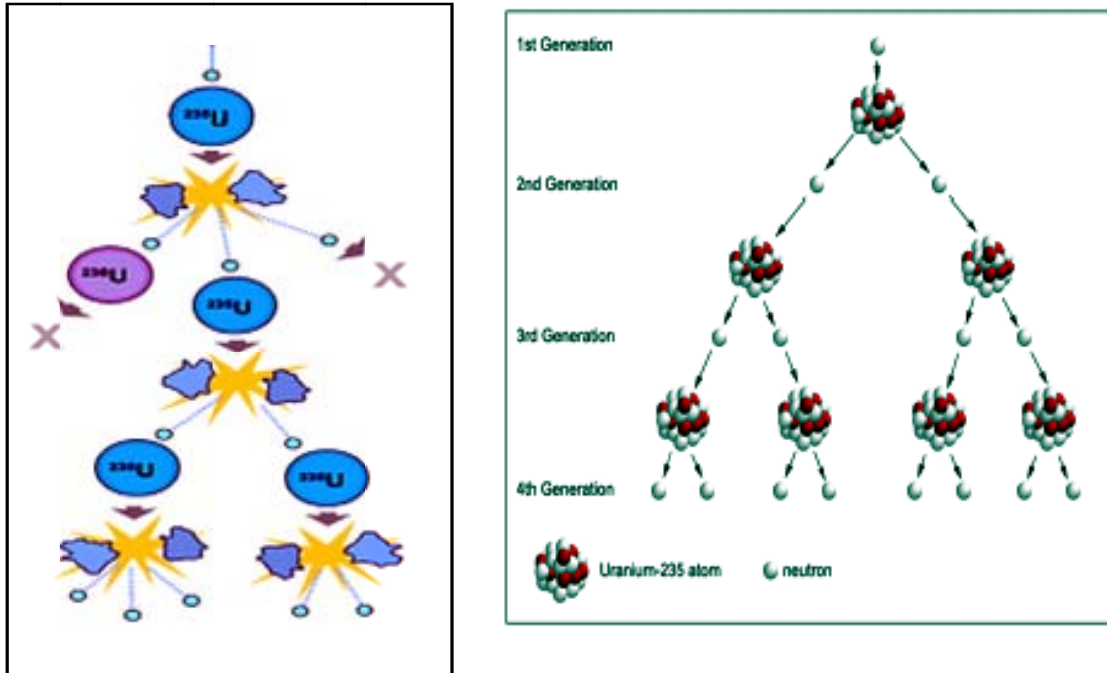

Figure 8.4 : Fission Chain Reaction

1st Generation: on average 2 neutrons

....

k^{th} Generation: $2k$ neutrons

Mean Generation Time Λ is the average time from a neutron emission to a capture that results in a fission $\Lambda = 10^{-7} - 10^{-8}$ c

80th generation in $10^{-5} - 10^{-6}$ c: during this time $2^{80} = 10^{24}$ neutrons are produced which lead to

- the fission of 10^{24} nuclei (140 g) of ^{235}U
- = release of **$3 \cdot 10^{13}$ Watt of energy** ($1\text{W} = 1\text{J}/\text{c}$, $1\text{eV} = 1.602 \cdot 10^{-19}\text{J}$)
- which is equivalent to 1000 tonnes of oil.

- Controlled chain reactions are possible with the isotopes ^{235}U , ^{233}U and ^{239}Pu .
- *The chemical element isotopes that can sustain a fission chain reaction are called nuclear fuels, and are said to be fissile.*
- The most common nuclear fuels are ^{235}U (the isotope of uranium with an atomic mass of 235 and of use in nuclear reactors) and ^{239}Pu (the isotope of plutonium with an atomic mass of 239).

The effective neutron multiplication factor, k , is the average number of neutrons from one fission that causes another fission.

$$k = \frac{\text{number of neutrons in one generation}}{\text{number of neutrons in preceding generation}}$$

Fission chain reaction chain reactions are used

- ***Nuclear power plants*** operate by precisely controlling the rate at which nuclear reactions occur, and that control is maintained through the use of several redundant layers of safety measures. Moreover, the materials in a nuclear reactor core and the uranium enrichment level make a nuclear explosion impossible, even if all safety measures failed.
- ***Nuclear weapons*** are specifically engineered to produce a reaction that is so fast and intense that it cannot be controlled after it has started. When properly designed, this uncontrolled reaction can lead to an explosive energy release.

NUCLEAR ENERGY

The enormous amount of energy released during the nuclear fission is due to the loss in some mass. During nuclear fission, the sum of the masses of the products formed is slightly less than the sum of masses of target species and bombarding neutron. The loss in mass gets converted into energy according to Einsteins equation

$$\boxed{E = mc^2}$$

where, C = velocity

m = mass lose

E = energy

NUCLEAR REACTOR

Light Water Nuclear Power plant

Light water nuclear power plant is one in which U^{235} fuel rods are submerged in water. Here the water acts as coolant and moderator.

- The fission reaction is controlled by inserting or removing the control rods of B^{10} automatically from the spaces between the fuel rods
- The heat emitted by U^{235} in the fuel core is absorbed by the coolant
- Heat is transferred to sea water and then converted into steam.
- The steam then drives the turbines, generating electricity.

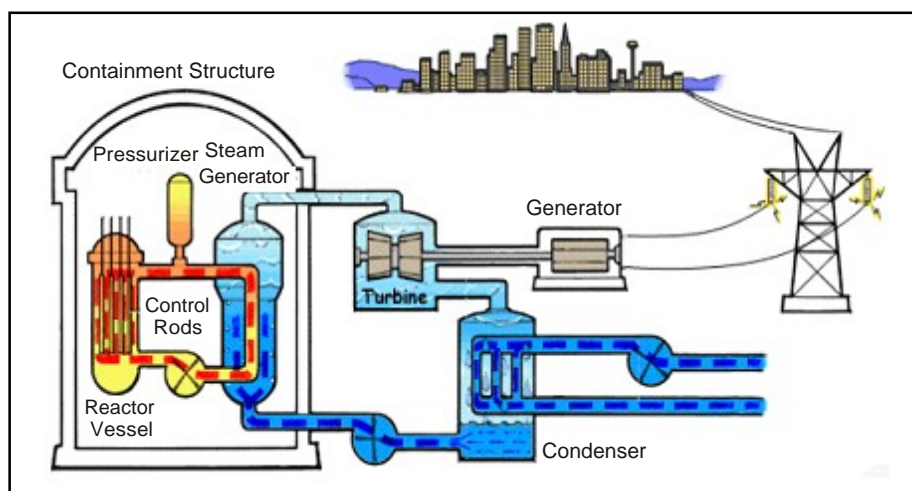
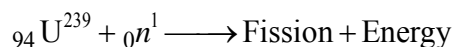
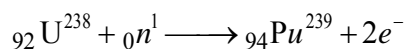

Figure 8.5 : Structure of light water nuclear power plant

Breeder Reactor

A nuclear reactor with conversion or multiplication factor greater than one is a breeder reactor. A breeder reactor generates fissionable nuclei from fertile nuclei. E.g., the fertile material like uranium-238 is converted into fissile ${}_{94}\text{Pu}^{239}$ by using slow neutrons. ${}_{94}\text{Pu}^{239}$ undergoes fission and produces energy.



- A breeder reactor is a nuclear reactor that generates new fissile or fissionable material at a greater rate than it consumes such material. These reactors were initially (1940s and 1960s) considered appealing due to their superior fuel economy; a normal reactor is able to consume less than 1% of the natural uranium that begins the fuel cycle, whereas a breeder can utilize a much greater percentage of the initial fissionable material, and with re-processing, can use almost all of the initial fissionable material.
- Breeders can be designed to utilize thorium, which is more abundant than uranium. Currently, there is renewed interest in breeders because they would consume less natural uranium (less than 3% compared to conventional light-water reactors), and generate less waste, for equal amounts of energy, by converting non-fissile isotopes of uranium into nuclear fuel.
- Production of fissile material in a reactor occurs by neutron irradiation of fertile material, particularly uranium-238 and thorium-232.
- In a breeder reactor, these materials are deliberately provided, either in the fuel or in a breeder blanket surrounding the core, or most commonly in both.
- Production of fissile material takes place to some extent in the fuel of all current commercial nuclear power reactors. Towards the end of its life, a uranium PWR fuel element is producing more power from the fissioning of plutonium than from the remaining uranium-235. Historically, in order to be called a breeder, a reactor must be specifically designed to create more fissile material than it consumes.

SOLAR ENERGY CONVERSION

In ancient times, wood was the most common source of heat energy. The energy of flowing water and wind was also used for limited activities. *Can you think of some of these uses?* The exploitation of coal as a source of energy made the industrial revolution possible. Increasing industrialization has led to a better quality of life all over the world. It has also caused the global demand for energy to grow at a tremendous rate. The growing demand for energy was largely met by the fossil fuels – coal and petroleum.

Our technologies were also developed for using these energy sources. But these fuels were formed over millions of years ago and there are only limited reserves. The fossil fuels are non-renewable sources of energy, so we need to conserve them. If we were to continue consuming these sources at such alarming rates, we would soon run out of energy! In order to avoid this,

alternate sources of energy were explored. But we continue to be largely dependent on fossil fuels for most of our energy requirements.

Energy development is increasingly dominated by major global concerns of over-population, air pollution, fresh water pollution, coastal pollution, deforestation, biodiversity loss, and global climate deterioration. To prevent disastrous global consequences, it would increasingly be impossible to engage in large-scale energy-related activities without insuring their sustainability, even for developing countries in which there is a perceived priority of energy development and use and power generation over their impact on the environment, society, and indeed on the energy sources themselves.

Solar Cells

A device which converts the solar energy (energy obtained from the sun) directly into electrical energy is called 'Solar cell'. This is also called as 'Photovoltaic cell'.

Principle

The basic principle involved in the solar cells is based on the photovoltaic (PV) effect. When sun rays fall on the two layers of semiconductor devices, potential difference between the two layers is produced. This potential difference causes flow of electrons and thus produces electricity.

Example: Silicon solar cell

Construction

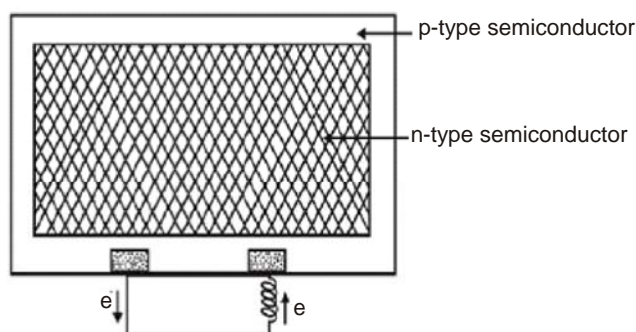

Figure 5.5 : Solar Cell

Solar cell consists of a p-type (such as Si doped with boron) and an n-type (such as Si doped with phosphorous) semiconductor plates. They are in close contact with each other.

Working

When the solar rays fall on the top layer of p-type semiconductor, the electrons from the valence band get promoted to the conduction band and cross the p-n junction into n-type semiconductor. Thereby potential difference between two layers is created, which causes flow of electrons (i.e. electric current). The potential difference and hence current increases as more solar rays falls on the surface of the top layer.

Thus, when this p- and n- layers are connected to an external circuit, electrons flow from n-layer to p-layer and hence current is generated.

Applications of Solar Cells

- (i) Solar cells are used in street lights.
- (ii) Water pumps are operated by using solar batteries.
- (iii) They are used in calculators, watches, radios and TVs.
- (iv) They are used for eco-friendly driving vehicles.
- (v) Silicon Solar cells are used as power source in space crafts and satellites.
- (vi) Solar cells can even be used in remote places and in forests to get electrical energy without affecting the atmosphere.

Wind Energy

Moving air is called wind. Energy recovered from the forces of wind is called wind energy.

- Wind power is the conversion of wind energy into a useful form, such as electricity, using wind turbines. At the end of 2008, worldwide nameplate capacity of wind-powered generators was 121.2 gigawatts (GW).
- Wind turbines produce electricity by using the natural power of the wind to drive a generator.

- The wind is a clean and sustainable fuel source, it does not create emissions and it will never run out as it is constantly replenished by energy from the sun.
- In many ways, wind turbines are the natural evolution of traditional windmills, but now typically have three blades, which rotate around a horizontal hub at the top of a steel tower.
- Most wind turbines start generating electricity at wind speeds of around 3-4 metres per second (m/s), (8 miles per hour); generate maximum 'rated' power at around 15 m/s (30mph); and shut down to prevent storm damage at 25 m/s or above (50mph).

Working

- Generating electricity from the wind is simple: Wind passes over the blades exerting a turning force. The rotating blades turn a shaft inside the nacelle, which goes into a gearbox.
- The gearbox increases the rotation speed for the generator, which uses magnetic fields to convert the rotational energy into electrical energy.
- The power output goes to a transformer, which converts the electricity from the generator at around 700 Volts (V) to the right voltage for the distribution system, typically between 11 kV and 132 kV.
- The regional electricity distribution networks or National Grid transmit the electricity around the country, and on into homes and businesses.

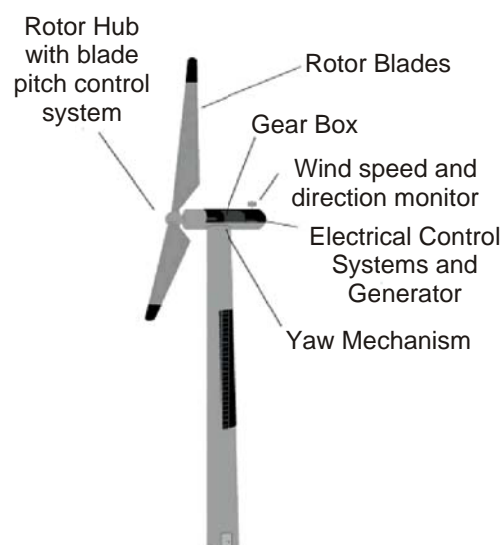

Figure 8.6 : Components of a typical wind turbine

Advantages

- (i) It is cheap and economical.
- (ii) It is renewable and
- (iii) It does not cause pollution.

Disadvantages

- (i) They produce noise.
- (ii) Wind farms erected on the migratory routes of birds create problems.
- (iii) Wind turbines interfere with electromagnetic signals.

CHAPTER 9: STORAGE DEVICES

BATTERIES

Battery is a device that stores chemical energy and releases it as electrical energy. Hence a device which converts chemical energy into electrical energy is called battery, cell, or storage battery.

A battery is an electrochemical cell which is often connected in series in electrical devices as a source of direct electric current at a constant voltage. A cell contains one anode and one cathode. The emf of a single cell is around 2 volt. A battery contains several anode and cathode. The emf of a battery which contains six anodes and six cathodes is around 12 V.

Batteries are classified as follows:

- (i) Primary battery
- (ii) Secondary battery and
- (iii) Fuel battery or Flow battery

Primary Battery

Primary battery is a cell in which the cell reaction is not reversible. Thus, once the chemical reaction takes place to release the electrical energy, the cell gets exhausted. They are use and throw type.

Example: Dry cell, Leclanche cell etc.

Dry Cell or Leclanche's Cell

A cell without fluid component is called as dry cell.

Example: Daniel Cell, Alkaline Battery.

Construction and Working

The anode of the cell is zinc container containing an electrolyte consisting of NH_4Cl , ZnCl_2 and MnO_2 to which starch is added to make it thick paste-like so that is less likely to leak. A graphite rod serves as the cathode, which is immersed in the electrolyte in the centre of the cell.

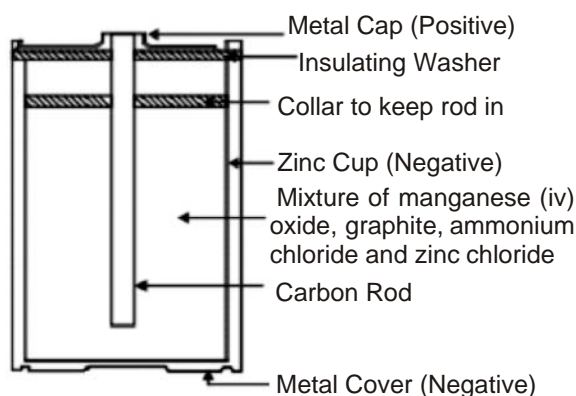
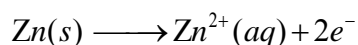

Figure 9.1 : Leclanche's Cell

The electrode reactions are given below.

Anodic Reaction



(Oxidation)

Cathodic Reaction

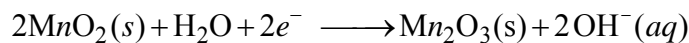

(Reduction)

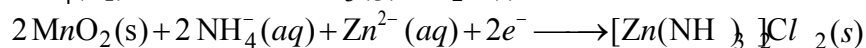
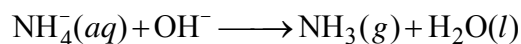

Overall Reaction

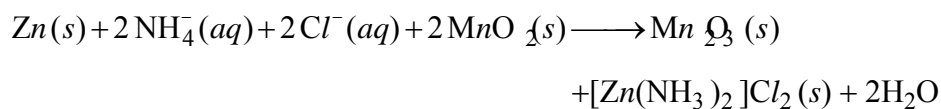

The dry cell is a primary battery, since no reaction is reversible by supplying electricity. Dry cell is very cheap to make. It gives voltage of about 1.5 V.

Advantages

- (i) When current is drawn rapidly, drop in voltage occurs.
- (ii) Since the electrolyte is acidic, Zn dissolves slowly even if it is not in use.

Uses

- Dry cells are used in flash-lights, transistor radios, calculators, etc

Secondary Battery

Secondary battery is a cell in which the cell reaction is reversible. They are rechargeable cells. Once the battery gets exhausted, it can be recharged.

Example: Nickel-Cadmium cell, Lead-acid cell (storage cell), etc.

Lead–Acid Storage Cell

The typical example for storage cell is Lead-acid storage cell. A secondary battery can operate as a voltaic cell and as an electrolytic cell. When it acts as a voltaic cell, it supplies electrical energy and becomes run down. When it is recharged, the cell operates as an electrochemical cell.

Construction and Working

A lead – acid storage cell consists of a number of voltaic cells (3 to 6) connected in series to get 6 to 12 V battery. In each cell, a number of Pb plates, used as anodes are connected in parallel and a number of PbO₂ plates, used as cathodes are connected in parallel. The plates are separated by insulators like rubber or glass fibre. The entire combination is immersed in 20% dil. H₂SO₄.

The cell is represented as:



When the lead-acid storage battery operates, the following cell reactions occur.

Anodic Reaction

Oxidation reaction takes place at anode. The electrons are released from anode. Hence the anode is called as negative anode and is represented as (-). Lead is oxidized to Pb^{2+} ions and gives two electron, which further combines with SO_4^{2-} to form insoluble $PbSO_4$.

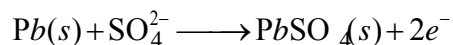

Cathodic Reaction

Reduction takes place at cathode. Hence the cathode is called as positive cathode and is represented as (+). PbO_2 is reduced to Pb^{2+} ions, which further combines with SO_4^{2-} to form insoluble $PbSO_4$.

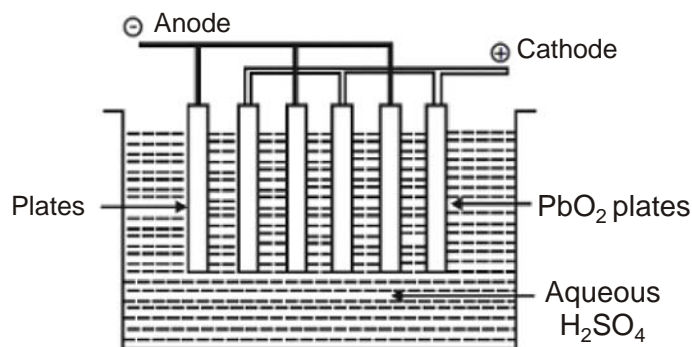
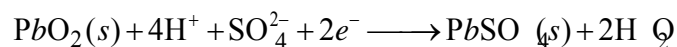
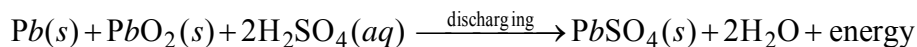

Figure 9.2 : Lead Storage Cell

Overall cell reaction during discharging



From the above cell reactions, it is clear that $PbSO_4$ is precipitated at both the electrodes and the concentration of H_2SO_4 decreases. So, the battery needs recharging.

Overall cell reaction during recharging

The cell can be recharged by passing electric current in the opposite direction. The electrode reaction gets reversed. As a result, Pb is deposited on anode and PbO_2 on the cathode. The concentration of H_2SO_4 also increases.

Advantages of Lead–Acid batteries

1. It is made easily.
2. It produces very high current.
3. The self-discharging rate is low.
4. It works effectively even at low temperatures.

Uses

1. Lead – acid batteries are used in cars, buses, trucks etc.
2. It is used in gas engine ignition, telephone exchanges, and power stations hospitals.
3. IT industry, educational institutions, laboratories etc.

Li–Ion Batteries

Li-Ion Batteries consist of a three primary functional components. The main components of a Li-ion battery device are the positive electrode, negative electrode and the electrolyte, for which a variety of materials may be used.

Generally, the most useful material for the positive electrode is one of three materials: lithium cobalt oxide, lithium iron phosphate, or a spinel such as lithium MnO_2 .

On the other hand, the most common materials for the negative electrode are carbon based compounds and lithium- containing alloys.

Upon charging, lithium ions are extracted from the positive electrode material and inserted into the negative electrode material. Upon discharging, the reverse process takes place. Common batteries should exhibit three characteristics:

- (a) high energy and power capacity,
- (b) high charging rate, and
- (c) long lifetime (cycling stability).

Although Li-ion batteries are available commercially, the performance of Li-ion batteries is limited by the current electrode and electrolyte materials. For future generations of rechargeable Li-ion batteries, not only for applications in portable electronic devices but especially for clean energy storage and use in hybrid electric vehicles, further improvements of materials are essential.

We need to find new, efficient and effective ways to improve the physical and chemical characteristics of the materials for use in electrochemical Li-ion batteries.

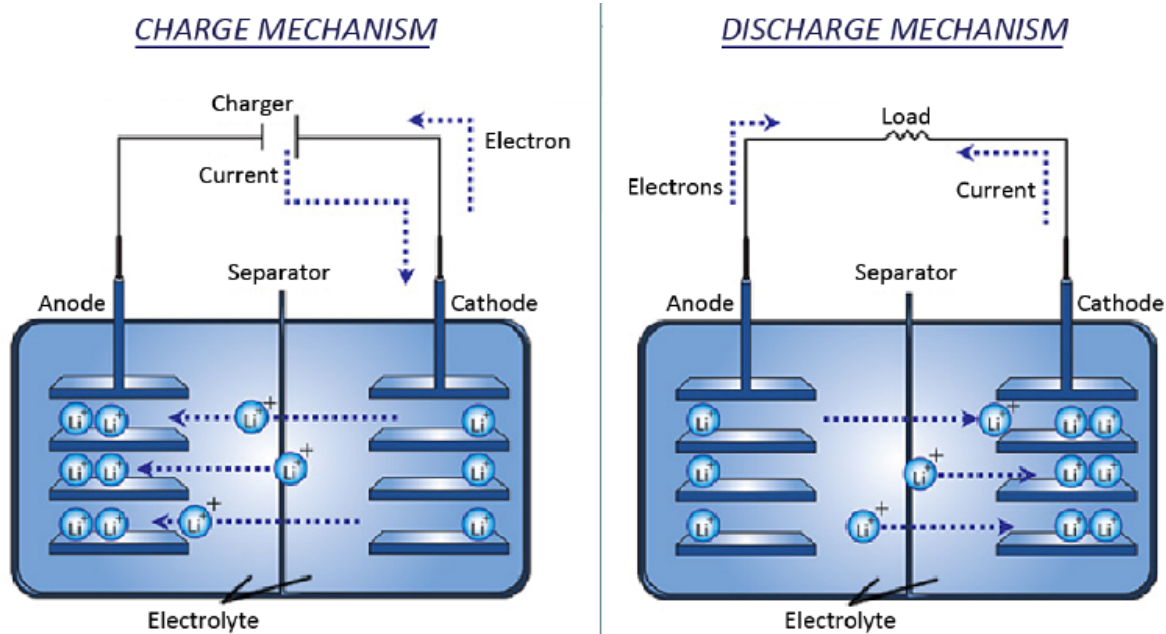

Figure 9.3 : Lithium ion cell during charging and discharging

Fuel Battery or Flow Battery

Flow battery is an electrochemical cell that converts the chemical reaction into electrical energy. When the reactants are exhausted, new chemicals replace them.

Example: Hydrogen-oxygen cell, Aluminium-air cell, etc.

In Aluminium-air cell, when the cell is exhausted, a new aluminium rod is used and the solution is diluted with more water as the electrochemical reaction involves aluminium and water.

FUEL CELLS

First developed by William Grove In 1839, Grove was experimenting on electrolysis (the process by which water is split into hydrogen and oxygen by an electric current), when he observed that combining the same elements could also produce an electric current.

A fuel cell is an electrochemical conversion device. It produces electricity from fuel (on the anode side) and an oxidant (on the cathode side), which react in the presence of an electrolyte. The reactants flow into the cell, and the reaction products flow out of it, while the

electrolyte remains within it. Fuel cells can operate virtually continuously as long as the necessary flows are maintained.

Fuel Cells are different from electrochemical cell batteries in that they consume reactant from an external source, which must be replenished – a thermodynamically open system. By contrast, batteries store electrical energy chemically and hence represent a thermodynamically closed system.

Many combinations of fuels and oxidants are possible. A hydrogen fuel cell uses hydrogen as its fuel and oxygen (usually from air) as its oxidant. Other fuels include hydrocarbons and alcohols. Other oxidants include chlorine and chlorine dioxide.

Classification of Fuel Cells

Based on the type of Electrolyte

1. Polymer Electrolytic Membrane Fuel Cell (PEMFC)
2. Direct Methanol Fuel Cell (DMFC)
3. Alkaline Fuel cell (AFC)
4. Phosphoric Acid Fuel cell (PAFC)
5. Molten Carbonate Fuel Cell (MCFC)
6. Solid Oxide Fuel Cell (SOFC)

Hydrogen Oxygen Fuel Cells

- In Polymer Electrolyte Membrane (PEM) fuel cells, protons move through the electrolyte to the cathode to combine with oxygen and electrons, producing water and heat.
- Polymer Electrolyte Membrane (PEM) fuel cell uses a polymeric membrane as the electrolyte, with platinum electrodes.
- These cells operate at relatively low temperatures.
- These cells are the best candidates for cars, for buildings and smaller applications. Polymer Electrolyte Membrane (PEM) fuel cells—also called proton exchange membrane fuel cells—deliver high power density and offer the advantages of low weight and volume, compared to other fuel cells.

- PEM fuel cells use a solid polymer as an electrolyte and porous carbon electrodes containing a platinum catalyst.
- They only hydrogen, oxygen from the air, and water to operate and do not require corrosive fluids like some fuel cells. They are typically fueled with pure hydrogen supplied from storage tanks or onboard reformers.
- The platinum catalyst is also extremely sensitive to CO poisoning, making it necessary to employ an additional reactor to reduce CO in the fuel gas if the hydrogen is derived from an alcohol or hydrocarbon fuel. This also adds cost.
- Developers are currently exploring platinum/ruthenium catalysts that are more resistant to CO.

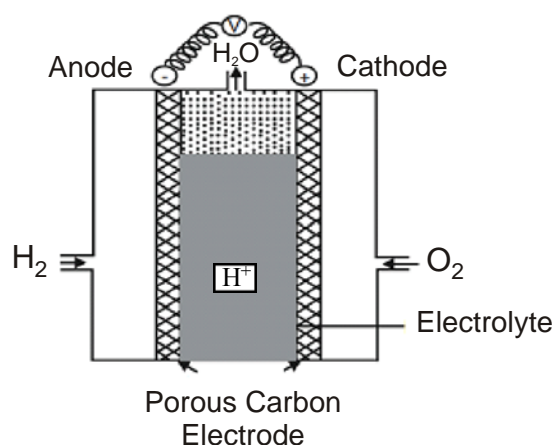
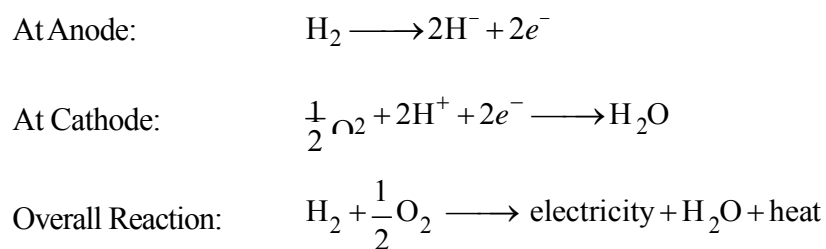

Figure 9.4 : Hydrogen-Oxygen Fuel Cells



Advantages

1. They are efficient and instant in operation.
2. They are pollution free.

3. They produce electric current directly from the reaction of a fuel and an oxidizer.
4. They are light in weight

Disadvantages

1. Fuel cells cannot store electric energy.
2. Electrodes are expensive and short lived.
3. H_2 should be pure.

Applications

1. H_2-O_2 fuel cells are used in space crafts, submarines to get electricity
2. In H_2-O_2 fuel cell, the product water is a valuable source of fresh water for astronauts.

SUPERCAPACITORS

Supercapacitors represent an important component for energy storage devices, particularly for short-acting high power batteries. Batteries suffer from a relatively slow power delivery or uptake, faster and higher-power energy storage systems are needed in a number of applications, and this role has been given to the supercapacitors.

- The highest performance supercapacitors are currently based on NSMs, given that increased electrode surface area improves the capacitance. It is the reason why so many researchers have been involved in working on different kinds of NSMs.
- In brief, supercapacitors are formed by two polarizable electrodes, a separator and an electrolyte. They utilize double layer capacitance where the ions of the electrolyte are adsorbed on the charged electrode, resulting in a Helmholtz layer.
- The Helmholtz double layer thickness is defined as half the diameter of the adsorbed solvated ions at the electrode/solution interface. The power density of supercapacitors is lower than that of batteries.

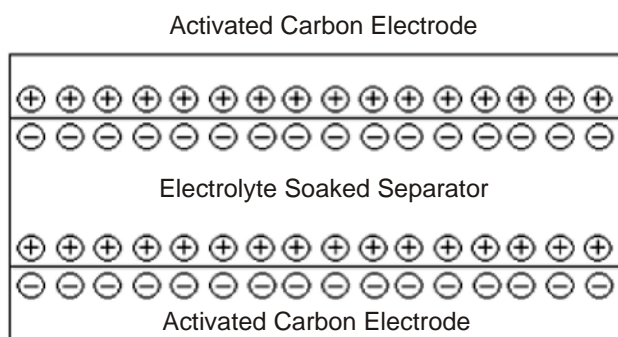

Figure 9.5 : Typical construction of a super capacitor

Therefore, the development of supercapacitors aims to improve the power density and significantly reduce cost. These electrochemical devices are also known as *ultracapacitors*, *pseudo capacitors*, and *Electric Double Layer Capacitors (EDLC)*.

